



# MASON INDUSTRIES, Inc.

Manufacturers of Vibration Control Products

350 Rabro Drive  
Hauppauge, NY 11788  
631/348-0282  
FAX 631/348-0279  
Info@Mason-Ind.com  
www.Mason-Ind.com

2101 W. Crescent Ave., Suite D  
Anaheim, CA 92801  
714/535-2727  
FAX 714/535-5738  
Info@MasonAnaheim.com  
www.MasonAnaheim.com

**ALL-DIRECTIONAL  
SEISMIC SNUBBER  
with CALIFORNIA  
OSHPD No. OPA-0197**

TYPE

# Z-1011

DATA SHEET DS-300A-2.2

## Z-1011 ALL-DIRECTIONAL SEISMIC SNUBBER Sizes 500 - 25000

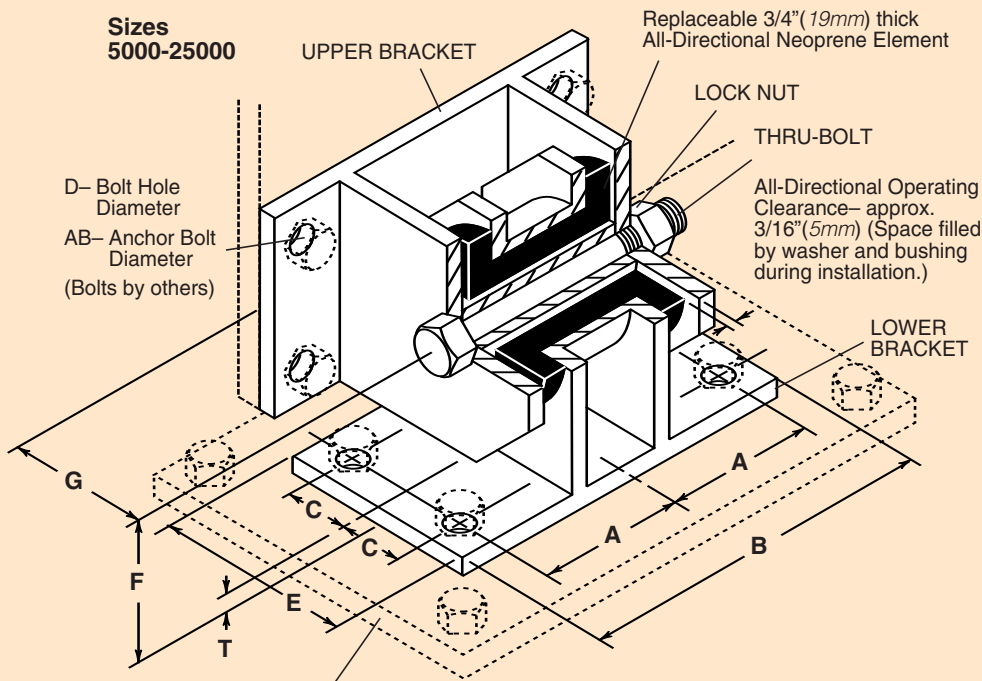

When Steel Sole Plates are used, level and anchor Sole Plates properly to concrete. Snubber Baseplate may be bolted or welded to Sole Plate.

### INSTALLATION INSTRUCTIONS:

- Snubbers are inactive during normal operation and clearance must be maintained.
- To maintain clearances around isolation bushing, unit is furnished with spacer washers and a spacer bushing, these to remain in unit during installation only.
- If snubbers are installed on equipment such as blowers or pumps with flexible connections that move and remain in a different position during operation, final positioning and adjustment of snubbers must be made with equipment in operation.
- Use shims at brackets as required so that units are installed without applying pressure on spacer washers or bushing.
- After units are installed, remove spacer washers and bushing as follows:
  - Remove lock nut from thru-bolt and remove thru-bolt.
  - Remove anchor bolts from one bracket. If bracket was shimmed, note shim position.
  - Remove bracket and remove spacer washers and spacer bushing.
  - Reinstall bracket and thru-bolt. Shim as before if shims were used.
  - Lock thru-bolt in place with jam nut.

Sizes 500-1250

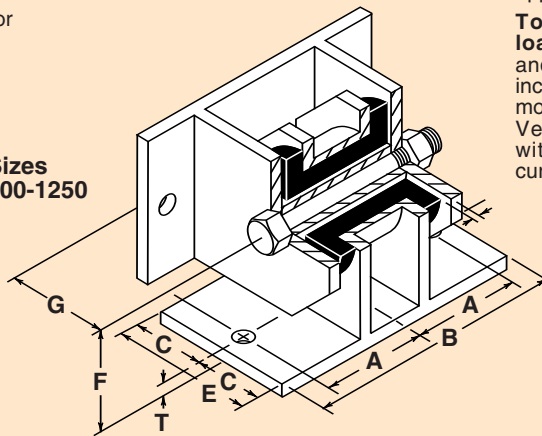

ALTERNATE 180° POSITION

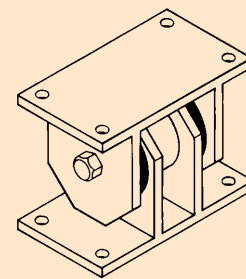

### OSHPD OPA-0197 Rated Load Curves— lbs kgs

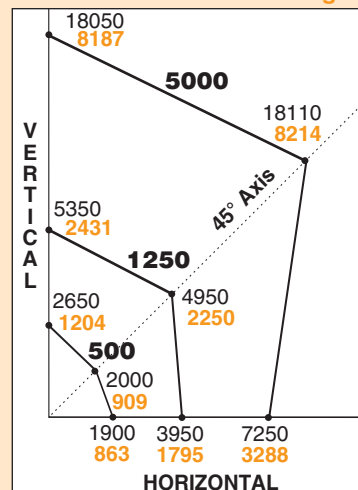

Horizontal, Vertical and 45° plotted Ratings are California OSHPD approved values having the OSHPD Anchorage Preapproval Number OPA-0197. Testing and calculations were performed to meet OSHPD criteria. Z-1011 snubbers sizes 500, 1250 & 5000 were submitted to OSHPD in November 2003 and are awaiting approval.

To use approved OSHPD rated load curves: 1) Calculate Vertical and Horizontal Forces on mounting including translations and overturning moments. 2) Plot Horizontal Load vs Vertical Load. The point must fall within the area below the OSHPD curve.

### TYPE Z-1011 1G ALL DIRECTIONAL LOAD RATINGS AND DIMENSIONS

Type	Size	1G All Directional Load Ratings	A	AB	B	C	D	E	F	G	T
U.S.A. or British (lbs & inches)	500	500 lbs.	31/8	3/8	71/2	11/2	1/2	3	21/2	3	1/4
	1250	1250 lbs.	33/8	1/2	81/4	3	5/8	6	43/8	43/8	3/8
	5000	5000 lbs.	5	5/8	121/2	21/2	3/4	7	5	5	1/2
	13000	13000 lbs.	6	1	141/2	23/4	11/8	8	53/4	53/4	3/4
Metric (kgs & mm)	25000	25000 lbs.	63/8	11/4	16	41/8	13/8	11	8	8	1
	500	227 kgs.	79	10	191	38	13	76	64	76	6
	1250	568 kgs.	86	13	210	76	16	152	111	111	10
	5000	2273 kgs.	127	16	318	64	19	178	127	127	13
	13000	5909 kgs.	152	25	368	70	29	203	146	146	19
	25000	11364 kgs.	162	32	406	105	35	279	203	203	25



**MASON INDUSTRIES, Inc.**  
Manufacturers of Vibration Control Products

350 Rabro Drive Hauppauge, NY 11788  
631/348-0282  
FAX 631/348-0279  
Info@Mason-Ind.com  
www.Mason-Ind.com

2101 W. Crescent Ave., Suite D  
Anaheim, CA 92801  
714/535-2727  
FAX 714/535-5738  
Info@MasonAnaheim.com  
www.MasonAnaheim.com

**ALL-DIRECTIONAL SEISMIC SNUBBER WITH CALIFORNIA OSHPD No. OPA-196**

TYPE

**Z-1225**

DATA SHEET DS-300B-2.2

**Z-1225 ALL-DIRECTIONAL SEISMIC SNUBBER Sizes 250 - 5000**

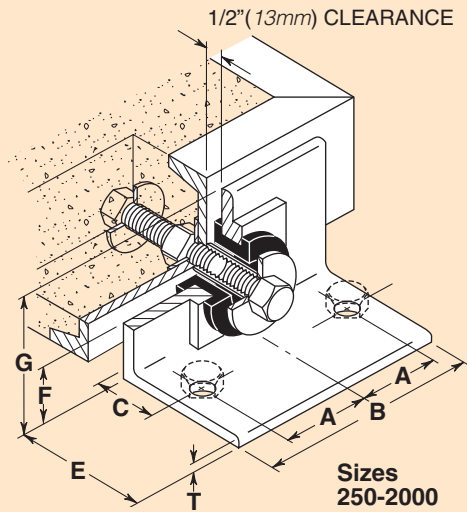
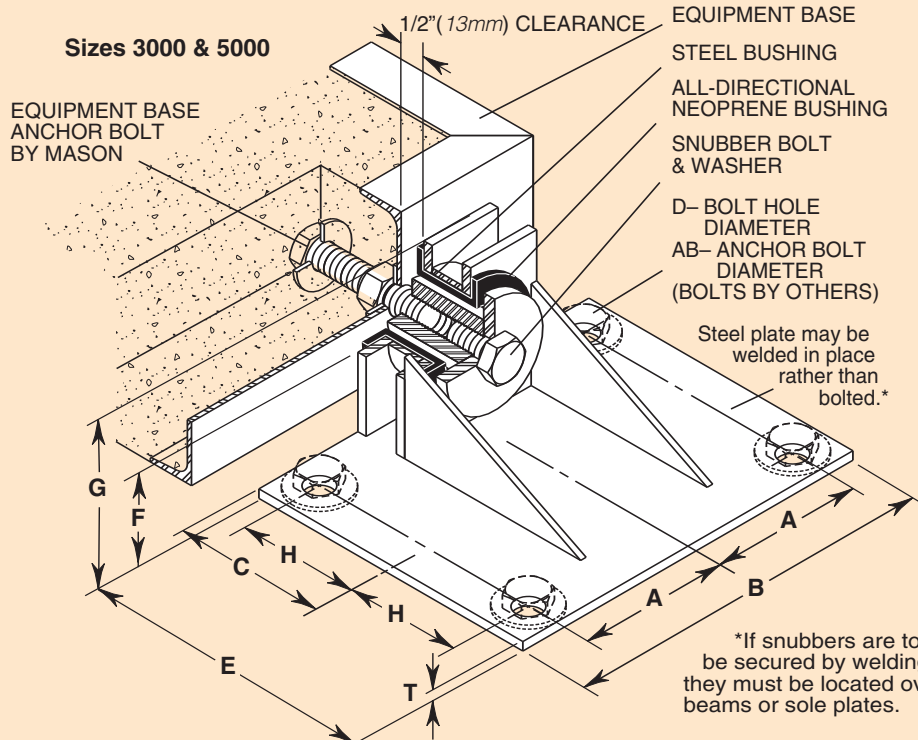

**OSHPD OPA-0196**  
Rated Load Curves— lbs kgs

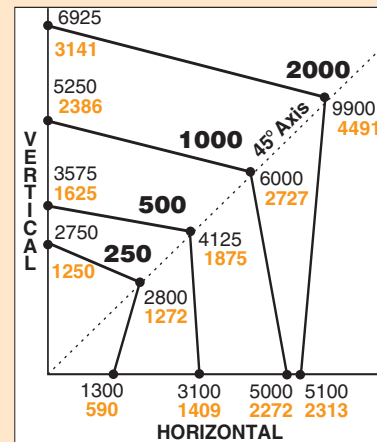

Horizontal, Vertical and 45° plotted Ratings are California OSHPD approved values having the OSHPD Anchorage Preapproval Number OPA-0196. Testing and calculations were performed to meet OSHPD criteria. Z-1225-2000 was submitted to OSHPD in November 2003 and is awaiting approval.

**To use approved OSHPD rated load curves:** 1) Calculate Vertical and Horizontal Forces on mounting including translations and overturning moments. 2) Plot Horizontal Load vs Vertical Load. The point must fall within the area below the OSHPD curve.

NOTES:

- Neoprene Bushings are 1/4" (6mm) thick throughout.
- All Operating Clearances are 1/4" (6mm).
- Set Base Anchor to protrude 3/4" (19mm) from face to face.
- A continuous rod, threaded on each end and protruding 3/4" (19mm) from both the faces of the base may be used to secure the threaded steel bushings in lieu of the individual Base Anchor Bolts.
- Normal clearance between base & floor is 1" (25mm).
- Distance from Base Anchor Bolt centerline to bottom of base is F minus 1" (25mm).
- When 2" (51mm) clearance between base and floor is specified, use 1" (25mm) spacer plate under snubber angle.

8. Earthquake restraining angles are to be installed after equipment is in operation to assure design clearances are maintained as follows:

- Remove snubber bolt and washer.
- Screw steel bushing on Base Anchor Bolt protrusion.
- Pass Restraining Angle over steel bushing so it is centered horizontally.
- Raise or lower base with spring adjustments or shim Restraining Angle so steel bushing is centered vertically.
- Set Restraining Angle so inside vertical face is 1/2" (13mm) clear of base and parallel to it.
- Mark and set AB anchor bolts or weld angle in position.
- Replace snubber bolt and washer and tighten in position.

**TYPE Z-1225 1G ALL DIRECTIONAL LOAD RATINGS AND DIMENSIONS**

Type	1G All Directional Load Ratings											Equipment Base Anchor Bolt Size & Length	
	Size	Load Ratings	A	AB	B	C	D	E	F	G	H	T	
U.S.A. or British (lbs & inches)	250	250 lbs	2	1/2	5	11/2	5/8	3	21/8	31/2	—	1/4	1/2"-13 UNC-4"
	500	500 lbs	23/4	1/2	7	2	5/8	4	23/8	4	—	1/4	5/8"-11 UNC-6"
	1000	1000 lbs	3	5/8	8	21/2	3/4	5	21/2	5	—	3/8	3/4"-10 UNC-6"
	2000	2000 lbs	5	3/4	12	3	7/8	6	3	6	—	1/2	3/4"-10 UNC-6"
	3000	3000 lbs	43/4	3/4	12	5	7/8	10	31/4	63/8	33/4	3/8	7/8"-9 UNC-6"
	5000	5000 lbs	6	1	15	6	11/8	12	31/2	63/8	43/4	3/8	1"-8 UNC-6"
Metric (kgs & mm)	250	113 kgs	51	13	127	38	16	76	54	89	—	6	1/2"-13 UNC-4"
	500	227 kgs	70	13	178	51	16	102	60	102	—	6	5/8"-11 UNC-6"
	1000	455 kgs	76	16	203	64	19	127	64	127	—	10	3/4"-10 UNC-6"
	2000	909 kgs	127	19	305	76	22	152	76	152	—	13	3/4"-10 UNC-6"
	3000	1364 kgs	121	19	305	127	22	254	83	162	95	10	7/8"-9 UNC-6"
	5000	2273 kgs	152	25	381	152	29	305	89	162	121	10	1"-8 UNC-6"