



MASON INDUSTRIES, Inc.

Manufacturers of Vibration Control Products

350 Rabro Drive
Hauppauge, NY 11788
631/348-0282
FAX 631/348-0279
Info@Mason-Ind.com
www.Mason-Ind.com

2101 W. Crescent Ave., Suite D
Anaheim, CA 92801
714/535-2727
FAX 714/535-5738
Info@MasonAnaheim.com
www.MasonAnaheim.com

DOUBLE DEFLECTION SWAY BRACE FOR MASONRY OR DRY WALL CONSTRUCTION

TYPE

DNSB

DATA SHEET DS-402-1.1 A

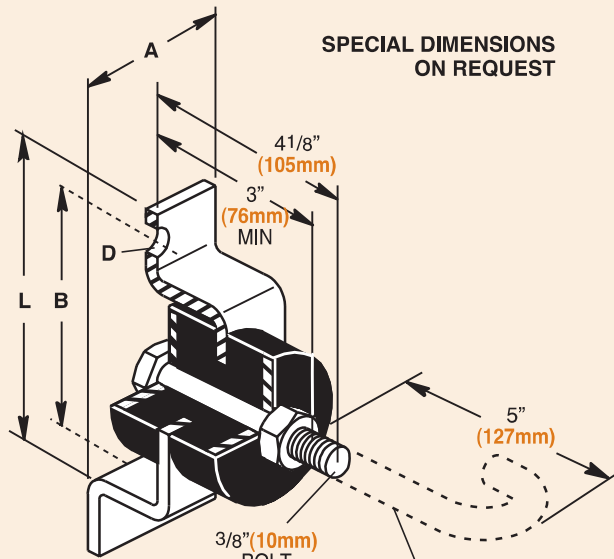

**SPECIAL DIMENSIONS
ON REQUEST**

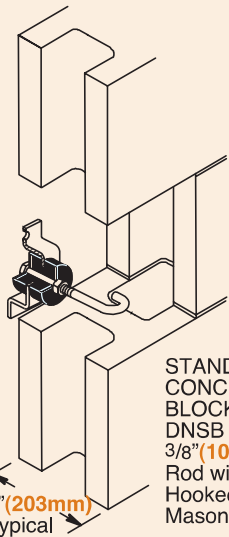

**STANDARD
CONCRETE
BLOCK END
DNSB Brace with
3/8" (10mm) Diameter
Rod with 2" (51mm) I.D.
Hooked End for
Masonry Walls**

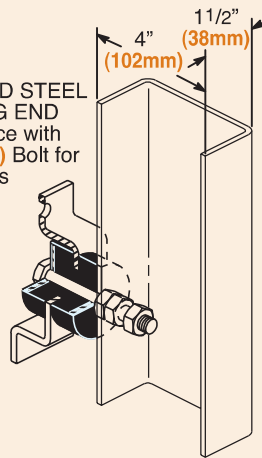

**STANDARD STEEL
STUDDING END
DNSB Brace with
3/8" (10mm) Bolt for
Metal Studs**

COMMON WALL WEIGHTS

Thickness (in) (mm)	Material	(lbs/ft ²) (kg/m ²)	Thickness (in) (mm)	Material	(lbs/ft ²) (kg/m ²)	
4 102	Brick	35 175	4 102	Steel Studding Alone	1.5 7.5	
8 203		75 365	2x4 51x102	Wood Studding Alone	2.0 10	
12 305		115 560				
4 102	Heavy	35 175	1/2 13	Gypsum Board	2.1 10	
6 152	Aggregate	50 245	5/8 16		2.7 13	
8 203	Hollow	58 285	3/4 19		3.2 16	
12 305	Concrete Block	90 440	1 25	Cement Plaster	10.0 50	
4 102	Concrete	48 235	1 25	Gypsum Plaster	5.0 25	
6 152		Poured	72 350	-	Metal Lathe	0.5 2.5
8 203		Masonry	96 470	-	Gypsum Lathing Board	2.0 10
12 305	Masonry	144 705				

PHYSICAL PROPERTIES OF BRIDGE BEARING NEOPRENE ELEMENTS

Grade (Durometer A)	60
Original Physical Properties	
Hardness ASTM-D676	60±5
Tensile strength, minimum psi ASTM-D412	2500
Elongation at break, minimum percentage	350
Accelerated Tests to Determine Long-term Aging Characteristics	
Oven Aging - 70 hrs @ 212 F, ASTM-D573	
Hardness, maximum change of points	+15
Tensile strength, maximum percentage of change	±15
Elongation at break, minimum percentage	-40
Ozone (1 ppm in air by volume @ 20% strain @ 100 + 2 F, ASTM-D1149, 100 hrs)	No Cracks
Compression Set, ASTM-D395 - Method B, 22 hrs at 158 F, maximum percentage of change	25

TYPE DNSB DIMENSIONS (in mm)

Type & Size	A	B	D Hole Diameter	L
DNSB-A DNSB-AM*	2 51	33/4 95	1/2 13	43/4 121
DNSB-B DNSB-BM*	2 1/2 64	4 1/4 108	1/2 13	5 1/4 133

TYPE DNSB LOAD RATINGS

Type & Size	Rated Axial Restraint & Deflection if Stressed				Maximum Assigned Wall Weight (lb) (kg)	Minimum Assigned Weight to Establish 10Hz (lb) (kg)	Resistance to Vertical Motion Created by Wall Pad or Floating Floor Deflection							
	Load (lb) (kg)	Defl (in) (mm)	Load (lb) (kg)	Defl (in) (mm)			Load (lb) (kg)	Defl (in) (mm)	Load (lb) (kg)	Defl (in) (mm)	Load (lb) (kg)	Defl (in) (mm)	Load (lb) (kg)	Defl (in) (mm)
DNSB-A DNSB-AM*	56 25	0.10 2.5	84 38	0.15 3.8	250 113	50 23	6 3	0.05 1.3	12 50	0.10 2.5	18 8	0.15 3.8	24 11	0.20 5.1
DNSB-B DNSB-BM*	260 118	0.10 2.5	390 177	0.15 3.8	1200 544	400 181	39 18	0.05 1.3	78 35	0.10 2.5	117 53	0.15 3.8	156 71	0.20 5.1

*"M" designates Hooked End for Masonry

- Sway braces prevent buckling or overturning of tall or long walls.
- Buckling forces are extremely small when braces are reasonably spaced both horizontally and vertically as the brace spacing maintains a very low l/r column ratio.
- Our general recommendation is spacing on four foot centers both horizontally and vertically.
- The maximum axial restraint rating is approximately 33% of the maximum assigned wall weight and extremely conservative.
- Vertical resistance information is provided for checking embedment requirements in walls and shear or pullout forces on both ends of the sway braces. Sway braces are not to be used for vertical supports.
- Response frequency is a function of the attached mass and the dynamic stiffness in the direction of vibration. The 10 Hz response is normally lower and more desirable than what is usually specified. Heavier weight assignments than the specified minimum will lower the response frequency by the square root of the ratio of the minimum weight to the assigned value multiplied by 10 Hz. Lighter loads will increase the frequency by the same proportion.
EXAMPLE: 8" Concrete Block Wall weighing 55 lbs. per sq/ft. Sway braces on 4 foot centers both ways.
Assigned Weight = 16 x 55 = 880 lbs.
Selection DNSB-B (Maximum 1200 lbs)
Frequency = 10Hz x $\sqrt{400/880}$ = 6.74 Hz