

HVAC UNIT suspended from 30N Hangers. SAFEFLEX Expansion Joints are installed in pipelines to reduce blade frequency vibration and noise

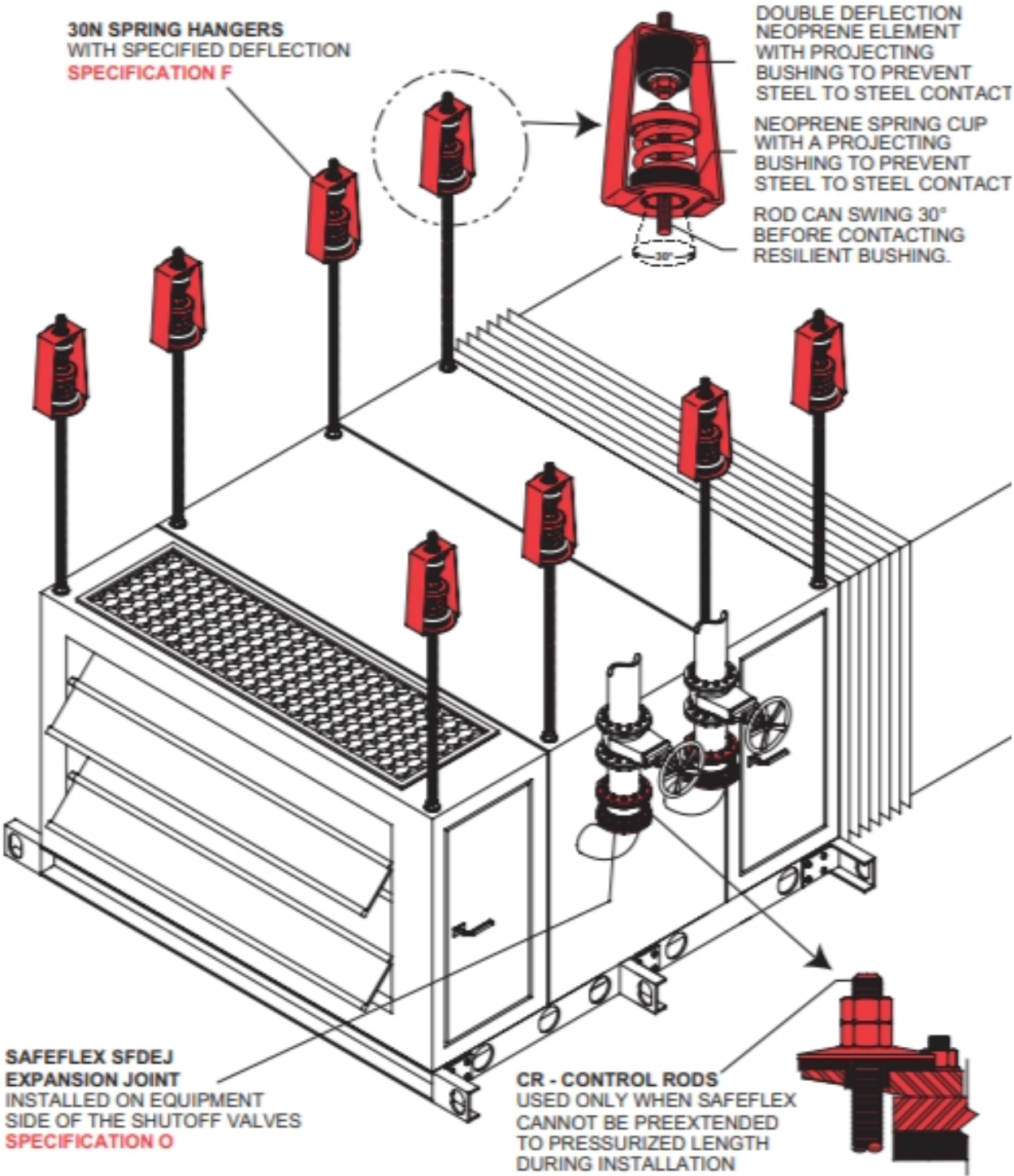

HVAC UNIT directly mounted on 1" deflection SLF Spring Mounts. SAFEFLEX Expansion Joints are installed in pipelines to reduce blade frequency vibration and noise

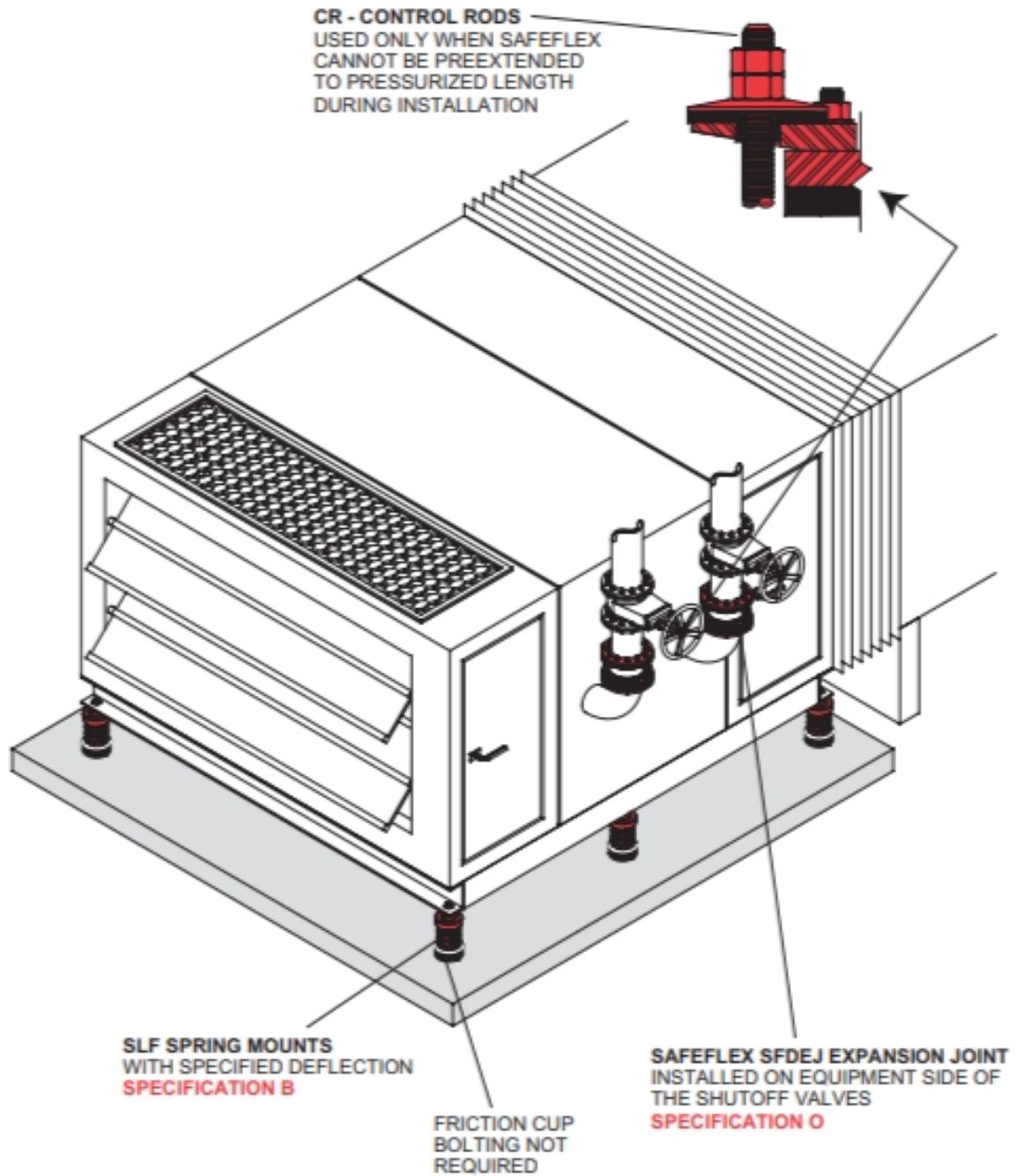

HVAC UNIT on WFSL Steel Base with height saving brackets and high deflection SLF Spring Mounts. SAFEFLEX Expansion Joints are installed in pipelines to reduce blade frequency vibration and noise

